

## POLIPASTO MANUAL DE CADENA

CÓDIGO	CARGA MAX (Kg)	ELEVACIÓN (m)	DIMENSIONES (mm)	Ø CADENA	PESO (Kg)
<b>8410210105</b>	500	2,5	300 x 240 x 180	6 mm	10
<b>8410210110</b>	1000	2,5	300 x 240 x 180	6 mm	10
<b>8410210120</b>	2000	2,5	300 x 240 x 180	6 mm	14



## POLIPASTOS MANUAL DE PALANCA

CÓDIGO	CARGA MAX (Kg)	ELEVACIÓN (m)	DIMENSIONES (mm)	Ø CADENA	PESO (Kg)
<b>8410210207</b>	750	1,5	145 X 320 X 122	6 mm	7,5
<b>8410210215</b>	1500	1,5	175 X 380 X 130	8 mm	10,5
<b>8410210230</b>	3000	1,5	203 X 408 X 150	10 mm	16,2
<b>8410210260</b>	6000	1,5	530 X 210 X 210	10 mm	27,5

POSIBILIDAD DE SUMINISTRAR CON **3 METROS** DE ELEVACIÓN



## POLIPASTOS ELÉCTRICOS DE CADENA

CÓDIGO	CARGA (Kg)	POTENCIA (W)	ELEV. (m)	Ø CADENA	VELOCIDAD ELEVACIÓN (m/min)	DIMENSION (mm)	PESO (Kg)
<b>8410210403</b>	150	205	6	4 mm	2,3	320 x 300 x 250	8
<b>8410210406</b>	300	410	6	5 mm	3	370 x 370 x 280	15
<b>8410210402</b>	500	540	6	6,3 mm	2,8	480 x 370 x 320	19



**TRANSPALETA MANUAL PROFESIONAL**

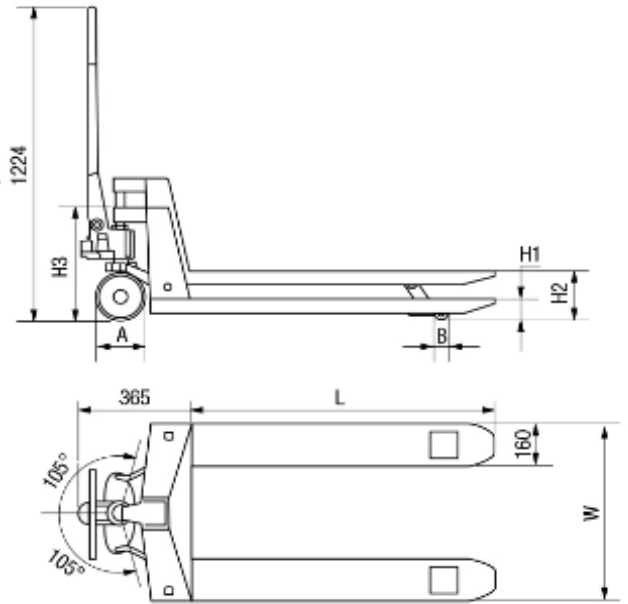

CÓDIGO	CARGA MAX (Kg)	H2 (mm)	H1 (mm)	L (mm)	W (mm)	B (mm)	A (mm)	RUEDA	PESO (Kg)
<b>8440060001</b>	2500	200	85	1.150	550	80	200	POLIURET.	71

**TRANSPALETA DE TIJERA**

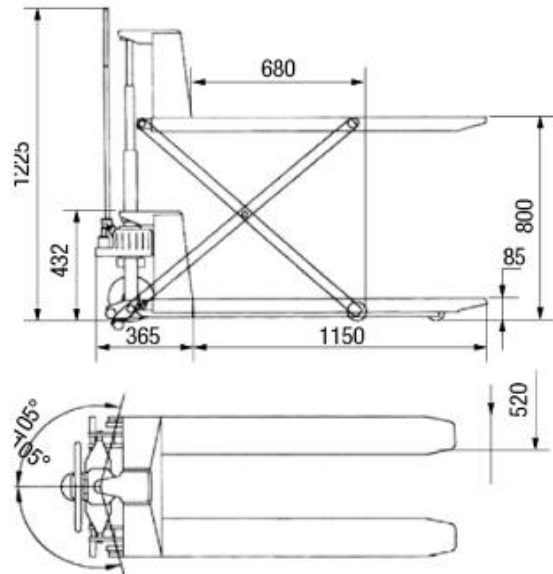

CÓDIGO	CARGA MAX (Kg)	ALTURA ELEVACION (mm)	DESCENSO HORQUILLA (mm)	LONGITUD HORQUILLA (mm)	ANCHO HORQUILLA (mm)	RUEDA	RUEDAS HORQU. (mm)	PESO (Kg)
<b>8440060021</b>	1000	800	85	1.150	520	POLIURET	74	110

## MESAS HIDRÁULICAS DE ACCIONAMIENTO MANUAL

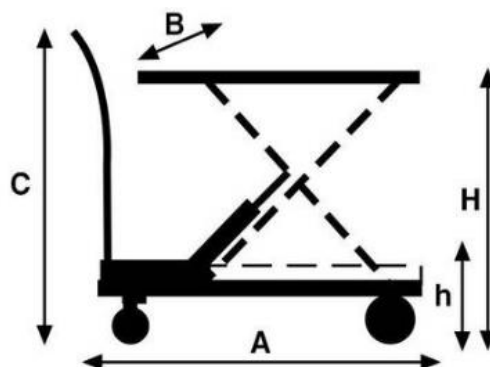

CÓDIGO	CARGA MAX (Kg)	MEDIDAS (A x B)	C (mm)	H (mm)	H (mm)	PESO (Kg)	IMPULSO MAX ALTURA	ELEVAC MAX	RUEDA
8440100001	150	700 x 450	950	220	720	46	28	720	Ø100
8440100003	300	850 x 500	990	285	880	77	27	880	Ø125
8440100005	500	935 x 450	1000	280	900	76	27	900	Ø 127
8440100007	750	1220 x 610	1010	450	1500	183	70	1500	Ø 150
8440100010	1000	1200 x 610	1010	380	1000	183	56	-	-
8440100015	1500	1200 x 610	1010	380	1000	183	56	-	-
8440100105	500	1600 x 810	990	290	915	154	55	915	Ø 127
8440100110	1000	2035 x 750	1000	360	1400	198	55	1400	Ø 180

## MESAS HIDRÁULICAS DE ACCIONAMIENTO ELÉCTRICO

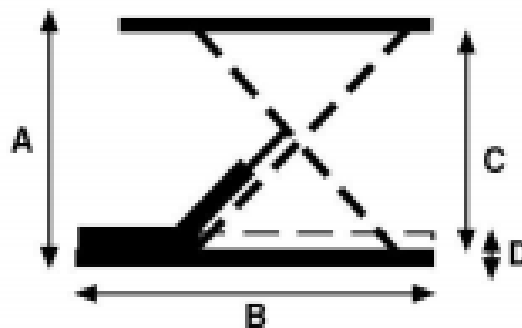

CÓDIGO	CARGA MAX (Kg)	ELEVACIÓN MIN (mm)	ELEVACIÓN MAX (mm)	MEDIDAS	A mm	B mm	C mm	D mm	TIEMPO ELEVACIÓN	TENSIÓN (V/Hz)
8440110005	500	190	1010	1300 x 800	1010	1300	820	190	15"	400/ 50
8440110010	1000	190	1010	1300 x 800	1010	1300	820	190	25"	400/ 50
8440110020	2000	190	1010	1300 x 800	1010	1300	820	190	40"	400/ 50
8440110030	3000	230	1020	1300 x 800	1020	1300	800	220	26"	400/ 50

## APILADORES MANUALES

- ✓ Sistema de elevación hidráulica que permite levantar, desplazar y apilar cargas aprovechando al máximo el espacio vertical
- ✓ Son especialmente útiles para la carga y descarga de materiales desde camiones y furgonetas
  - 3 puntos de control para mejor manejo
  - Sistema de freno manual
  - Doble sistema de elevación, por pedal y por mango

### ELEVACION 1.600 MM

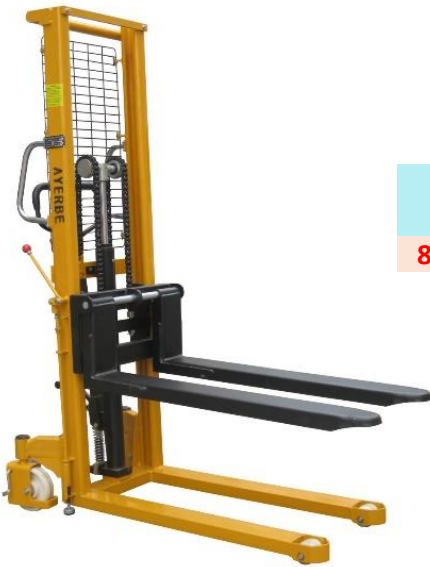

CÓDIGO	CAPAC.MAX (Kg)	ELEV. MAX	ALTURA MIN	DIMENSIONES (mm)	RADIO GIRO	PESO (Kg)
<b>8440080002</b>	1000	1600	1950	1670x550x1950	1100	195

### ELEVACION 2.500 MM



CÓDIGO	CAPAC.MAX (Kg)	ELEV. MAX	ALTURA MIN	DIMENSIONES (mm)	RADIO GIRO	PESO (Kg)
<b>8440080003</b>	1000	2500	1830	1550x540x1830	1250	290
<b>8440080004</b>	1000	3000	2090	1550x540x1830	1250	315

**CARRETILLA PLATAFORMA FIJA**



CÓDIGO	RUEDA	CAPACIDAD MAX.
8440030201	IMPINCHABLE	300 Kg

**CARRETILLA PLEGABLE**



CÓDIGO	CAPACIDAD MAX.	MEDIDAS (PLEGADO)
8440030301	90 Kg	60x480x730 mm

**CABALLETE DE RODILLO**



CÓDIGO	Ø EJE	ALTURA
8110210101	Ø52x350 mm	690/1200 mm

**CARRETILLA CON RUEDA**



CÓDIGO	L	MEDIDAS BANDEJA
8440030001	60 L	800X640
8440030019		RUEDA PARA CARRETILLA

**CARRO PORTAHERRAMIENTAS**



CÓDIGO	RESISTENCIA	MEDIDA
8110030101	150 Kg	590x400x905
8110030102	350 kg	800x500x930