

PUNTOS FIJOS

DIN 806WS Acero Especial Tratado y Rectificado

CÓDIGO	CM	ØD	L	ANG
6530010001	1	12,2	80	60°
6530010002	2	18	100	60°
6530010003	3	24,1	125	60°
6530010004	4	31,6	160	60°
6530010005	5	44,7	200	60°



DIN 806E Punto Fijo con Punta de Metal Duro

CÓDIGO	CM	ØD	L	ANG	Ød
6530020001	1	12,2	80	60°	7
6530020002	2	18	100	60°	7
6530020003	3	24,1	125	60°	11
6530020004	4	31,6	160	60°	14
6530020005	5	44,7	200	60°	18



DIN806HE Media Punta de Metal Duro

CÓDIGO	CM	ØD	L	ANG	D	L1
6530030001	1	12,2	80	60°	7	22
6530030002	2	18	100	60°	7	30
6530030003	3	24,1	125	60°	11	38
6530030004	4	31,6	160	60°	14	50
6530030005	5	44,7	200	60°	18	63

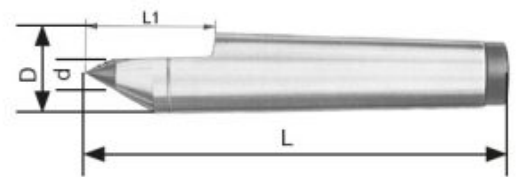

PUNTOS GIRATORIOS

Punta 60° precisión

CÓDIGO	CM	ØD	L	L1	D1	ANG
6530110001	1	36	114	17	15	60°
6530110002	2	45	129	24	20	60°
6530110003	3	60	160,5	31	25	60°
6530110004	4	70	205	41	32	60°
6530110005	5	90	258,5	50,5	40	60°

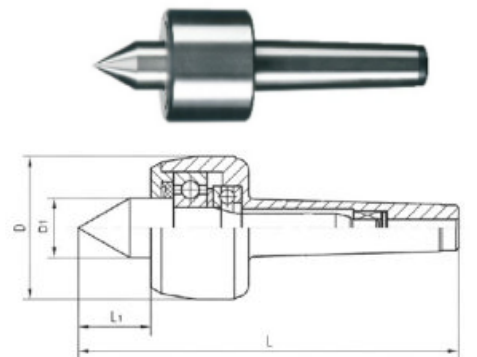

Punta 30°/60° prolongación

CÓDIGO	CM	ØD	L	L1	D1	ANG.
6530130002	2	45	139	34	20	30°/60°
6530130003	3	60	176,5	47	25	30°/60°
6530130004	4	70	217	53	32	30°/60°
6530130005	5	90	273	65	40	30°/60°
6530130006	6	105	354,5	78	50	30°/60°

